

STAINLESS STEEL GATE VALVE SCREWED END BSPT

Model: ARV-101SE

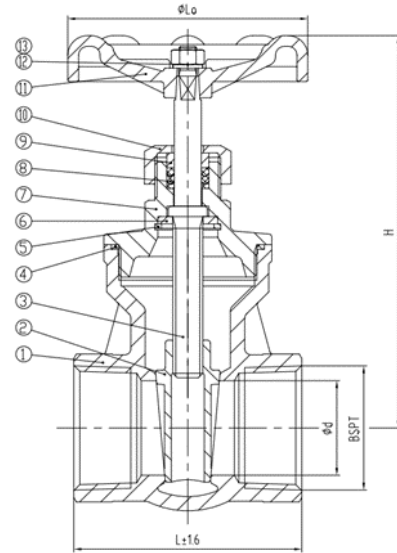

TECHNICAL DATA

SPECIFICATION STANDARDS

Design according to: BS 5154
Threaded end according to BSPT
Hand-Wheel Operator (Red or Blue Color)
Test and Inspection EN 1266
Working pressure: 1.6 Mpa, 2.5 Mpa
Working temperature: Max 120°C
Applicable medium: Water, Oil, Gas

STANDARD MATERIALS OF MAIN PARTS

ITEM	PART NAME	MATERIAL
1	BODY	CF8/ CF8M
2	DISC	CF8/ CF8M
3	STEM	STAINLESS STEEL
4	GASKET	PTFE
5	RING	STAINLESS STEEL
6	WASHER	STAINLESS STEEL
7	BONNET	STAINLESS STEEL
8	PACKING	PTFE
9	GLAND	STAINLESS STEEL
10	PACKING NUT	STAINLESS STEEL
11	HANDWHEEL	ALUMINIUM
12	SPRING WASHER	STEEL
13	NUT	STEEL

DIMENSION (mm)

DN	INCH	L	Ød	ØLo	H
15	½"	55	14	70	92
20	¾"	60	20	70	101
25	1"	68	25	80	113
32	1 ¼"	76	32	80	133
40	1 ½"	80	40	100	153
50	2"	93	50	100	171
65	2 ½"	113	63	140	205
80	3"	137	72	140	226